

# Hydro-pneumatic Handtool for Avlug® Speed Fasteners

## 7536 Model

### Features

- Lightweight tool with a separate intensifier
- Control box and air cursor for use of small diameter fasteners
- Uses same placing equipment and common parts of the 7530 tool
- Long reach barrel
- Can be suspended from a balancer (optional)

### Benefits

- Reliable placing of small diameter fasteners
- High placement speed
- Reduced operator fatigue
- Optimised ergonomic performance for improved productivity
- Ease of maintenance
- Productive time is maximised
- Consistent actuation and hence joint formation
- Can be used in many difficult access applications



### Specifications

Weight (pistol only)	1.2 kg (2.6 lbs)
Pull Force @ 5.5 bar	3.89 kN (875lbf)
Stroke min.	25 mm (0.98ins)
Cycle Time	1.0 sec
Air Supply Pressure	5 – 7 bar
Free Air Volume @ 5.1 bar	2.6 litres
Noise Level	< 70 dB(A)
Vibration	< 2.5m/s <sup>2</sup>
Intensification ratio	32:1

### Placing capability

Avdel Avlug® speed fastener  $\varnothing$  1.6 mm (1/16"). For detailed information on placing capability and nose equipment please refer to the tool manual on our website [www.avdel-global.com](http://www.avdel-global.com) or contact your local Avdel representative.

### Dimensions (mm/inch)

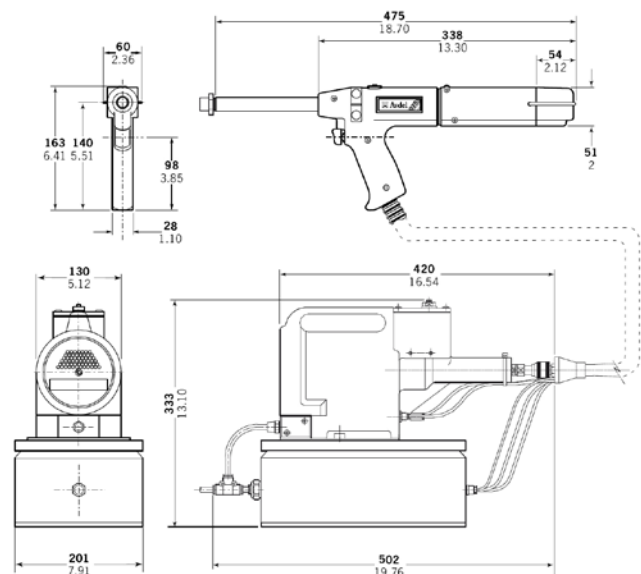

Avdel USA LLC  
614 NC Highway 200 South  
Stanfield, North Carolina 28163  
Tel. +1 704 888-7100 · Fax -0258  
[infoAvdel-USA@infastech.com](mailto:infoAvdel-USA@infastech.com)

[www.avdel-global.com](http://www.avdel-global.com)

Avdel Canada Limited  
1030 Lorimar Drive  
Mississauga, Ontario L5S 1R8  
Tel. +1 905 364-0664 · Fax -0678  
[infoAvdel-Canada@infastech.com](mailto:infoAvdel-Canada@infastech.com)

© 2010 Infastech

Avlug® is a trademark of Avdel UK Ltd.

07.2011

Data shown is subject to change without prior notice as a result of continuous product development and improvement policy. Your local Avdel representative is at your disposal should you need to confirm latest information.