

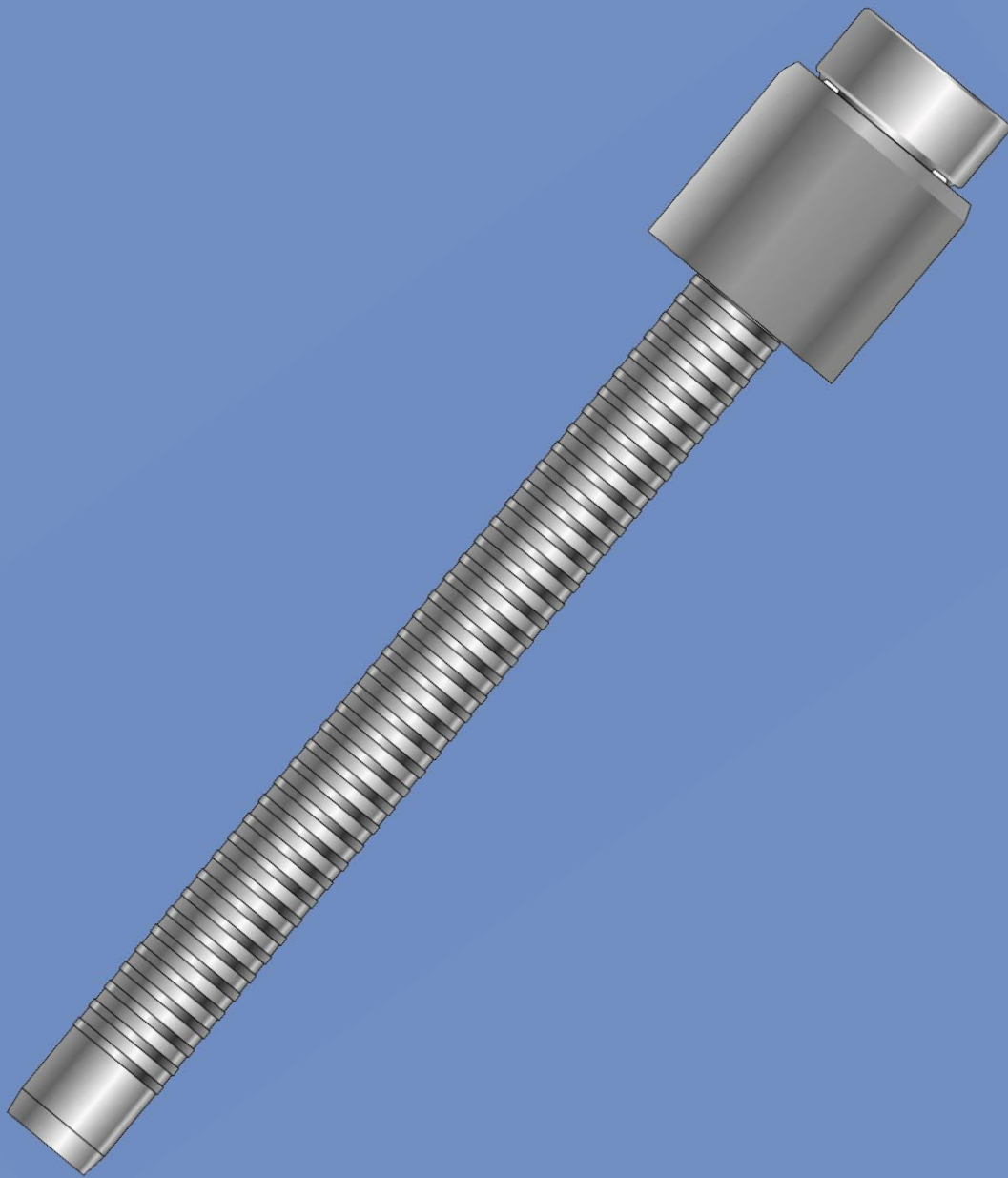

Avseal[®] II Blind Sealing Plug



Avseal[®] II

The new range of Avseal[®] II blind sealing plugs is unique in the efficient sealing performance provided in low- and high-pressure hole sealing applications. The rapidly installed two-piece plug offers technical characteristics that:

- Greatly improve quality and safety in demanding applications
- Simplify hole preparation and the installation process
- Offer an increased number of potential applications
- Lower assembly costs



Key features and benefits

- Fully annealed sleeve for high performance sealing
- Hole fill capacity for improved seal and wider hole tolerance
- Larger hole tolerance simplifies hole alignment when automated placing is required
- Seal by compression of the sleeve improves sealing with great hole fill capability over a wider hole tolerance
- Internal lock – flat nose tip and ease of use
- Improved stem retention increases vibration resistance
- No locking ring formed by nose tip allows use of standard equipment and reduces preventative maintenance
- Low force special version can be used in thin wall applications
- Tapered sleeve and stem eases entry into application and nose tips, making Avseal[®] II suitable for automated systems
- Shorter placed length, reduced blind side protrusion for use in restricted space or thin wall applications
- Can be modified to suit specific applications
- Use of standard tooling – quality of seal is not operator-dependant

Typical placing sequence

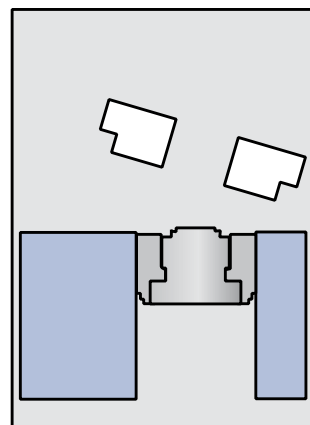
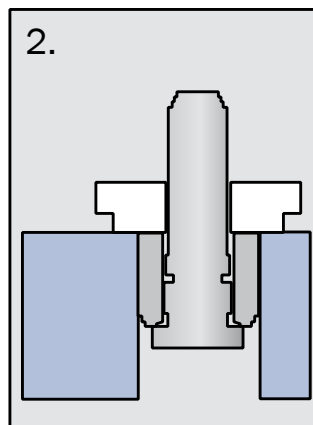
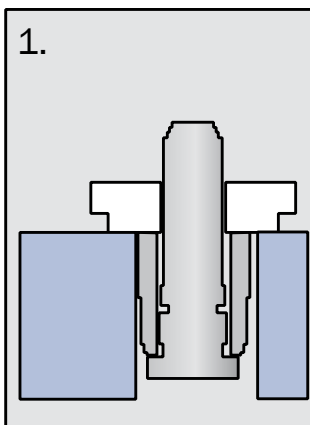

- 1) The Avseal[®] II sealing plug is located on the tool nose tip and inserted in the hole
- 2) On activating the tool, axial compression of the sleeve between the stem head and the nose tip of the tool creates the radial expansion of the sleeve
- 3) Once placed to a pre-determined load the pintail of the stem will break away leaving the Avseal[®] II sealing plug in the application

Blind Sealing Plug

Range

- Aluminium sleeve and steel stem
- Series 2961: \varnothing 4 - 12 mm for high pressure applications (> 300 bar)
- Series 2964: \varnothing 8 - 16 mm with reduced radial expansion force for low pressure applications (< 300 bar)



Product details

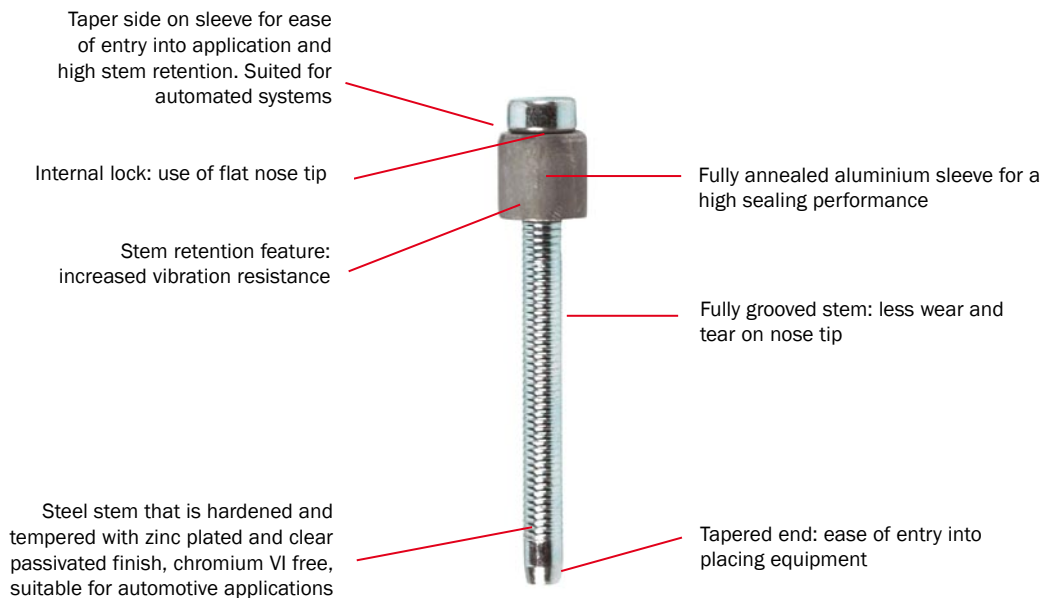

- Designed for both low-pressure and high-pressure blind hole sealing applications
- High leak resistance
- Exceptional hole fill
- Efficient stem locking device
- Wide choice of installation tools



Avseal® II

Performance

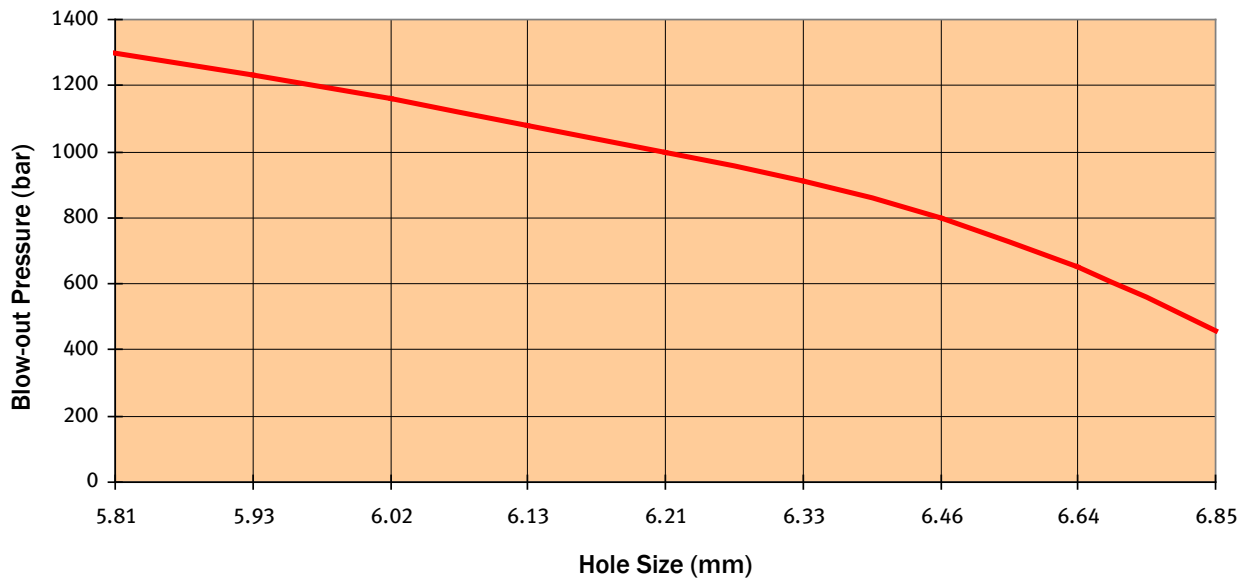

Average blow-out pressure at different hole sizes using the example of 6 mm Avseal® II series 2961

Tested in steel M257 (BS 970 230 M 07), hole roughness 2 µm

Performance data of other diameters available on request.

Performance data are reference data only. Applied tests are required in every case. Contact your Avdel representative for assistance.

Ideal Applications

High versatility

- Thin wall applications
- Restricted space
- Shorter hole length
- High pressure applications
- Holes with large tolerance

Automotive

- Engine blocks
- Transmissions
- Cylinders
- Brakes
- Clutch
- Gear box

Industrial

- Fluid handling
- Pneumatic systems
- Hydraulic blocks
- Compressors
- Refrigeration
- Pumps
- Gear box



Cylinder heads



Gear boxes



Valves



Pumps



Hydraulic components



Counterbalance cover

Blind Sealing Plug

Recommendations

For more detailed information please contact your local Avdel representative.

1. Hole size

- (i) When increasing the hole size, there is less contact with the hole area. Ultimate pressure capacity reduces and the placed length decreases.
- (ii) When an Avseal® II plug is used in a minimum or middle hole, standard or extended flat nose tips are suitable.
- (iii) When an Avseal® II sealing plug is used in a middle to maximum hole diameter, use only an extended nose tip.

2. Hole roughness

Recommended hole roughness is 50 to 250 µinch R_a (1.3 to 6.3 µm R_a).
Hole roughness below these values will reduce ultimate pressure capability.

3. Depth in hole: specific nose tips

According to required depth in hole, different nose tips can be used:

- Flush: flat nose tip
- 2 mm step
- 8 mm step

When depth in hole is below 1.5 x hole diameter, it is recommended to use an Avseal® II sealing plug with short sleeve option.



4. Wall thickness and hole distance

Depends on the application material. Detailed information on hole spacing calculation is available on request.

5. Sealing pressure versus material specification

Avseal® II plugs perform differently according to material of application. Tests must be performed on each material. The chart is an example of performance according to different materials with an Avseal® II plug ø 10 mm, high pressure version in 10.2 mm hole size.

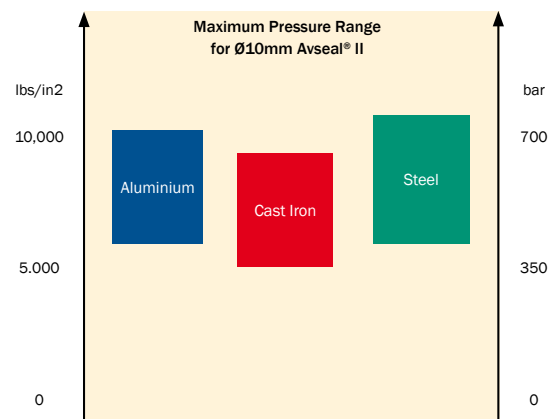

6. Removal procedure

Avseal® II sealing plugs can be removed from the work piece by using a Genesis® nG3 tool and an Avseal® II removal kit.

Another Avseal® II plug can be placed in the same hole.

7. Increased pressure resistance: stepped hole

In case of requirement for improved pressure resistance, a stepped hole is necessary:

- Up to 30,000 lb/in² (2070 bar) for a 10 mm, high pressure version
- 3x pressure push out performance

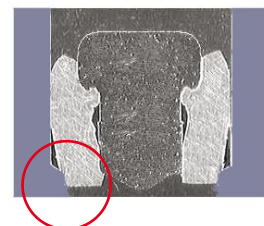

Avseal® II 2961 Series

Technical data



High pressure series

Sleeve: Aluminium Alloy BS1473/4/5 - 6061/AA6061 EN 573-3 AlMg1SiCu Werkstoff 3.3211

Stem: Carbon steel BS 3111 type 10 DIN 1654 35B2
 hardened and tempered
 Zinc plated, colourless
 passivation with top seal

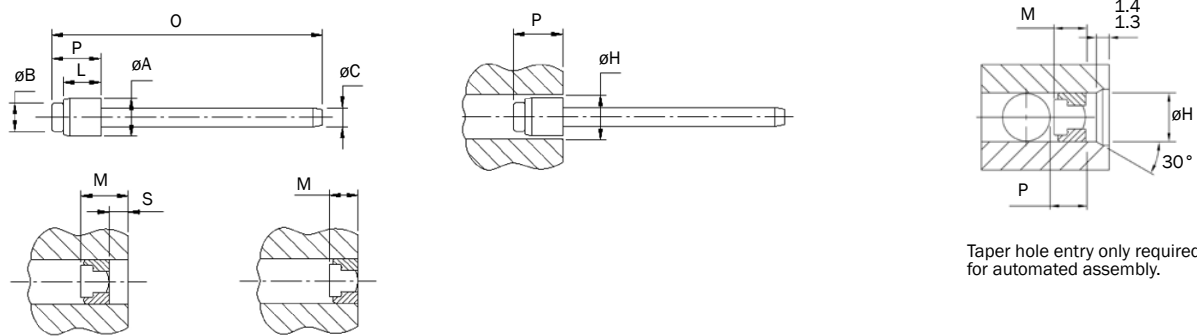

ø	O max.	øB ref.	øA max.	L max.	øC ref.	øH			P ¹⁾ req.	M ¹⁾		Part No/ref
						min.	max.	rec.		min.	max.	
4.0	41.4	3.0	3.9	4.1	1.9	3.9	4.3	4.1	6.50	2.81	4.32	02961-00405
5.0	42.2	3.8	4.9	5.0	2.2	5.0	5.4	5.0	7.14	3.95	5.70	02961-00506
6.0	50.1	4.5	5.9	6.0	2.6	6.0	6.4	6.0	8.53	4.30	8.73	02961-00607
7.0	51.1	5.4	6.8	6.9	3.0	7.0	7.4	7.0	9.78	5.15	9.17	02961-00708
8.0	51.9	6.1	7.8	7.9	3.6	7.8	8.4	8.0	11.05	7.18	9.41	02961-00810
9.0	53.0	6.9	8.8	8.5	3.9	8.8	9.8	9.0	12.70	7.64	9.84	02961-00911
10.0	53.4	7.8	9.8	10.0	4.4	9.8	10.8	10.0	14.00	8.77	13.00	02961-01012
11.0	61.5	8.6	10.8	11.9	4.8	10.8	11.8	11.0	15.07	TBA ²⁾	14.00	02961-01113
12.0	62.8	9.4	11.8	11.5	5.3	11.8	12.8	12.0	15.75	10.66	14.55	02961-01215

all dimensions in mm

1) Values for use with a flat nose tip (except for 4.0 & 5.0 mm where only stepped nosetips are available):
 - Add „S“ = 2 mm / 8 mm to „P“ and „M“ values when a 2 mm / 8 mm extended nose tip is used

2) To be announced

Avseal® II 2964 Series

Technical data



Low pressure series

Sleeve: Aluminium Alloy BS1473/4/5 - 6061/AA6061 EN 573-3 AlMg1SiCu Werkstoff 3.3211

Stem: Carbon steel BS 3111 type 10 DIN 1654 35B2
 hardened and tempered
 Zinc plated, colourless
 passivation with top seal

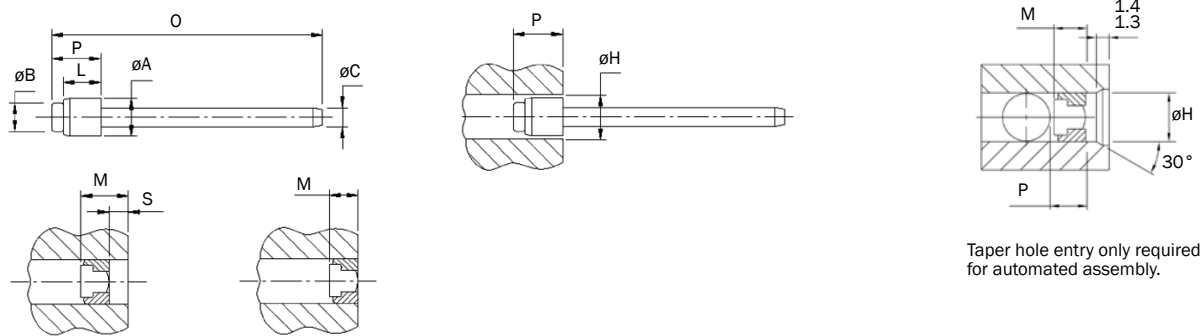

Taper hole entry only required for automated assembly.

ø	O max.	øB ref.	øA max.	L max.	øC ref.	øH			P ¹⁾ req.	M ¹⁾		Part No/ref
						min.	max.	rec.		min.	max.	
8.0	50.8	6.0	7.9	7.8	3.55	8.0	8.15	8.0	9.90	7.50	9.50	02910-10790
9.0	51.8	6.1	8.8	8.5	3.58	9.0	9.4	9.0	11.71	7.19	10.57	02964-00911
10.0	52.6	7.0	9.8	9.5	3.90	10.0	10.4	10.2	13.05	8.81	11.46	02964-01012
11.0	53.4	7.8	10.8	9.8	4.40	11.0	11.4	11.2	13.66	9.41	12.11	02964-01113
12.0	53.4	7.8	11.8	9.5	4.40	12.0	12.4	12.2	13.43	9.45	11.96	02964-01215
13.0	62.0	8.6	12.8	10.3	4.80	13.0	13.4	13.2	14.74	10.04	12.51	02964-01315
14.0	62.8	9.4	13.8	11.0	5.30	14.0	14.4	14.2	15.65	11.70	13.87	02964-01415
15.0	63.3	10.2	14.8	13.4	5.60	15.0	15.4	15.2	16.95	TBA ²⁾		02964-01520
16.0	64.8	11.0	15.8	12.6	6.00	16.0	16.4	16.2	18.04	13.88	16.00	02964-01620

all dimensions in mm

1) Values for use with a flat nose tip (except for 4.0 & 5.0 mm where only stepped nosetips are available):
 - Add „S“ = 2 mm / 8 mm to „P“ and „M“ values when a 2 mm / 8 mm extended nose tip is used

2) To be announced

Avseal® II

Installation tools

The Avseal® II range can be installed with the current selection of structural hand tools and automated placing equipment. The tapered end of the plug's stem ensures it is easy to feed

into the tooling equipment, while the taper on the sleeve allows ease of entry into an application.

Hand tools



Range of Genesis® nG models



722 model



734 model

Multi-head workstations

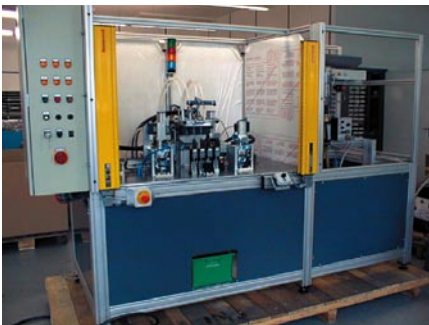

Multi-head systems, low cost solutions, manual feeding. Designed according to customer's specifications.

Automated systems

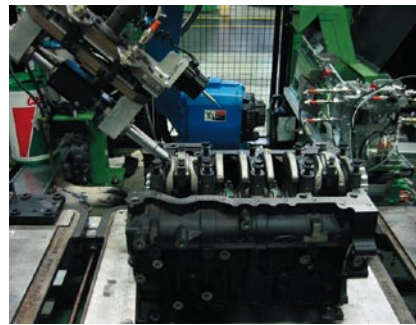

Fully automated Viking® system can be robot mounted and integrated into unmanned production cells.

Customer example

Application consists of sealing redundant oil galleries on cylinder heads and blocks in order to improve the total quality of the engines. Oil leaks are undesirable for the engines and lead to a negative impact on quality image.

An automated Viking® placing system is integrated into unmanned production cells and three Avseal® II plugs are placed in 22 seconds.

Placing matrix	Recommended Hand Tools				Recommended Automated Viking®			
	Dia.	nG2 (71213/4)	nG4 (71234)	7220	734	Module 1	Module 2	Module 3
4, 5, 6	H	H				H		
7	H	H				H		
8		H				H		
9		H, L				L	H	
10, 11, 12		L					L	
13, 14			L				L	
15, 16				L				L

H = 2961 series (High pressure version) L = 2964 series (Low pressure version) Other tools available, please ask your Avdel contact.



www.avdel-global.com

Avdel UK Limited
Pacific House, 2 Swiftfields
Welwyn Garden City, Hertfordshire AL7 1LY
Tel. +44 (0)1707 292-000 · Fax -199
enquiries@infastech.com

© 2010 Infastech

Avdel Patent Protected. Avdel®, Avseal®, Genesis®, and Viking® are registered trademarks of Avdel UK Limited. Data shown is subject to change without prior notice as a result of continuous product development and improvement policy. Your local Avdel representative is at your disposal should you need to confirm latest information.

06a.2009